

Lab 1

Diode Characteristics

Purpose

The purpose of this lab is to study the characteristics of the diode. Some of the characteristics that will be investigated are the I-V curve and the rectification properties. The Zener diode characteristics will also be studied at.

Material and Equipment

NI ELVIS
1N5404 Diode
1N4730 Zener Diode
1N4148 Diode
1N34 Diode
Assorted Resistor(5100Ω)

Pre lab

This lab does not require a pre lab. However, the rest of the labs may require the pre lab in the form of calculations, research and/or design.

Theory

The diode is a device formed from a junction of n-type and p-type semiconductor material. The lead connected to the p-type material is called the **anode** and the lead connected to the n-type material is the **cathode**. In general, the cathode of a diode is marked by a solid line on the diode.

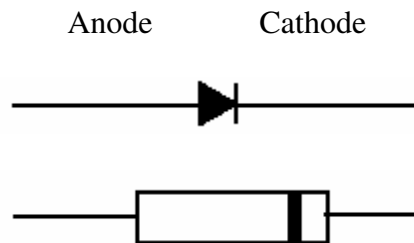

Figure 1-1: The symbol for a diode compared to an actual diode package.

The primary function of the diode is the rectification. When it is forward biased (the higher potential is connected to the anode lead), it will pass current. When it is reverse biased (the higher potential is connected to the cathode lead), the current is blocked. The characteristic curves of an ideal diode and a real diode are seen in Figure 1-2.

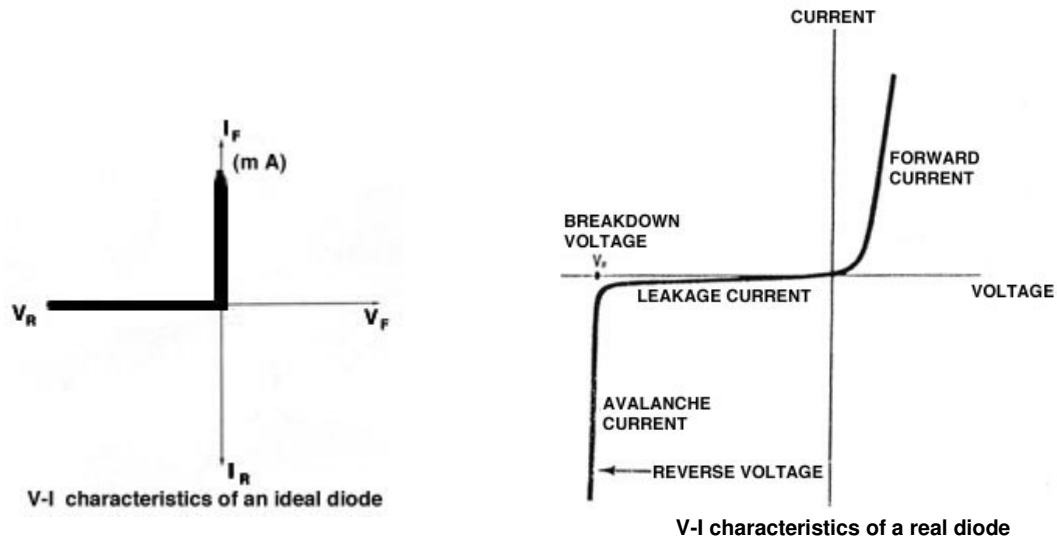

Figure 1-2

When analyzing circuits, the real diode is usually replaced with a simpler model. The simplest form, the diode is modeled by a switch (Figure 1-3). The switch is closed when the diode is forward biased and open when the diode is reverse biased.

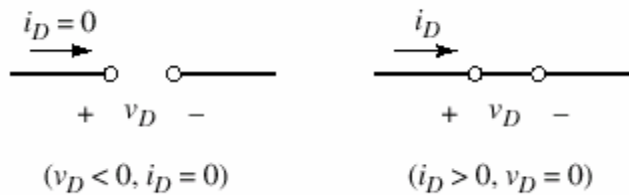

Figure 1-3 Equivalent Circuit of Diode

Procedure

1) Finding Diode specifications

Look up the characteristics of the diodes in your kit by making a web search. The specifications for different kinds of diodes vary. Copy all of the specifications for each diode as well as of the specification definitions for your final lab report.

2) Diode V-I Characteristics

The V-I characteristics for a diode can be displayed on Two-Wire Current-Voltage Analyzer.

- Connect the anode of the 1N4148 diode to the CURRENT HI terminal on the prototyping board and the cathode to the CURRENT LO terminal.
- Open the Two-Wire Current-Voltage Analyzer.
- Set the start voltage to -1V, stop voltage to 2V and the increment to 0.05
- Run the process.
- The current plot is displayed for the varying voltage across the diode. From this graph, obtain the cut-in voltage for the diode. From the point where current increases sharply draw a line to x axis as in Figure 1-4 below. The point where it intersects on x axis is called the cut-in voltage. (The plot may be different than below for a particular diode)

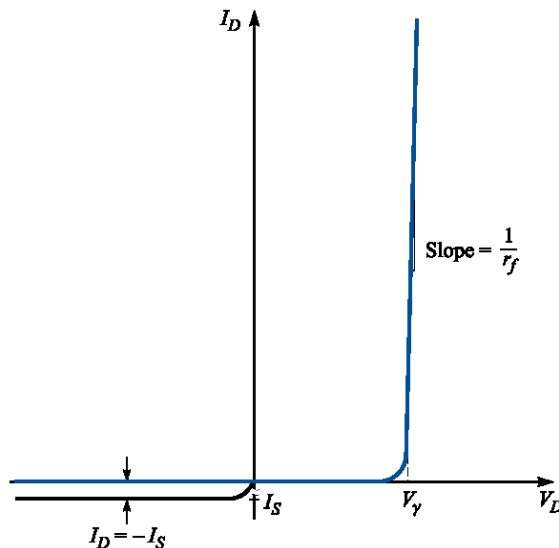

Figure 1-4 Equivalent Circuit of Diode

- Study the characteristics of various diodes provided. Repeat the procedure for 1N5404, 1N34 (germanium diode). If 1N5404 diode does not fit in breadboard holes, you may need to use wires to connect it.

3) Half-Wave Rectifier Properties

The half-wave rectifying properties of the diode can be displayed using the circuit shown in Figure1-5.

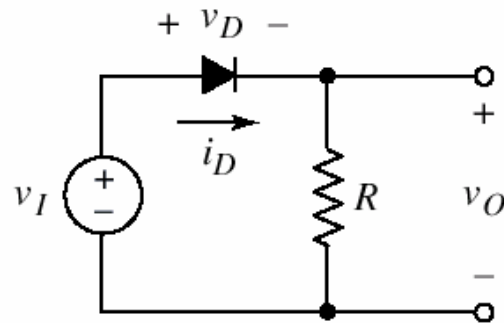

Figure 1-5

- The resistor (5100Ω) limits the current to very small values in the diode.
- Use 1N5404 diode (or 1N4148 diode whichever you prefer).
- Set the input voltage source to the circuit to an 4V p-p 1kHz sine wave.
- Measure and capture the waveforms for the input and output voltages, the diode voltage and the resistor current.

4) Zener Diode Characteristics

The Zener diode has the unique property of maintaining a desired reverse biased voltage. This makes it useful in voltage regulation. In this exercise, you are to tabulate the regulating properties of the Zener diode.

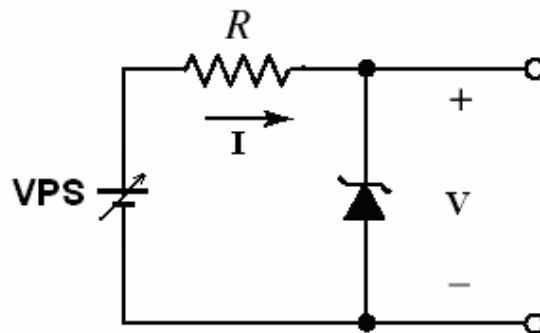

Figure1-5. Zener Diode Circuit

- Connect the circuit as in Figure1-5.
- Use 100Ω resistor and 1N4730 Zener diode.
- Measure the diode properties, by the varying the input voltage and measuring the voltage across the diode and the current.
- From your observations obtain the V_z .

Questions for the Lab Report

- 1) Compare the important features of a silicon versus a germanium diode.
- 2) What are the possible applications for the half wave rectifier circuit.
- 3) Define voltage regulation, cut-in voltage and all the terms in the diode current equation.